



PAIL # 61965

- LID # 60344 (Snap-on)
- LID # 63430 (Snap-on) T.S.
- LID # 63464 (Liquid Gasket) T.S.

TECHNICAL DATA

Capacity under lid:
 60344: 15.35 L / 4.06 US gal.
 63430: 15.30 L / 4.04 US gal.
 63464: 15.30 L / 4.04 US gal.

Wall thickness:
 Pail: (0.075 in.)
 Lid 60344: (0.055 in.)
 Lid 63430: (0.058 in.)
 Lid 63464: (0.058 in.)

Material: Pail: HDPE or PP (clear only)
 Lid: HDPE
Thermal range: -38°C (-36°F) to 82°C (180°F)
Standard color : white
 Other colors upon request

Weight (approx.) without handle or gasket:
Pail: (660 g) 23.28 oz
Lid 60344: (122 g) 4.30 oz
Lid 63430: (144 g) 5.08 oz
Lid 63464: (146 g) 5.20 oz



Handle: plastic / metal (with plastic grip)

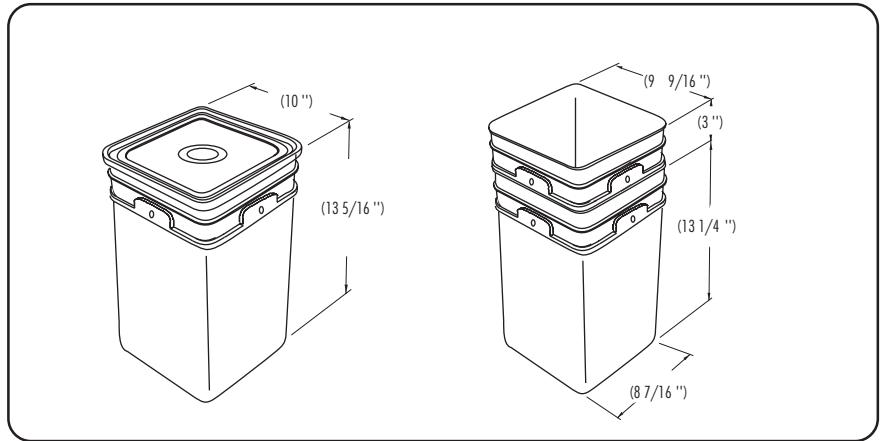

(Materials are recyclable or can be recovered for energy)

TOP LOADING RESISTANCE

60 kg (132 lb) at 23°C / 73°F, 30 days. Product temperature when filling pails and warehouse temperature will affect pail performance. IPL recommends to make necessary testing prior to full production.

PALLETIZATION OF FILLED PAILS

To determine the number of pails you can stack according to the product packed, divide the top loading resistance by the total weight of one filled pail. Take that number not rounded up and add the first unit

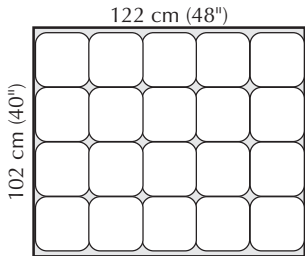

20 pails per layer

Stacked pails recommendation:
3 pails high/ pallet

RECOMMENDATIONS

- Do not exceed pallet edges with pails
- Staggered pattern is recommended for greater stability
- Double faced pallets with close together boards on both sides are recommended for best results
- To improve stability, release air from pail when putting the lid
- Stretch wrapping machine tension should be adjusted to pail
- Use slip-sheet to improve pails stability if necessary

Approvals: Virgin materials are approved for food contact and meet FDA (Food and Drug Administration USA) and HPB (Health Protection Branch Canada) regulations.

Advice: Handling conditions vary a lot from customer to customer, tests are recommended throughout the process of denesting, filling, conveying, palletization, warehousing, transportation and utilization by end users, etc. Specifications can be modified without notice. Please contact your IPL representative to confirm these data.

Quality Assurance:.. IPL is ISO 9001 certified and quality procedures are documented in our quality system.

PRINTING UP TO 6 COLORS DRY OFFSET

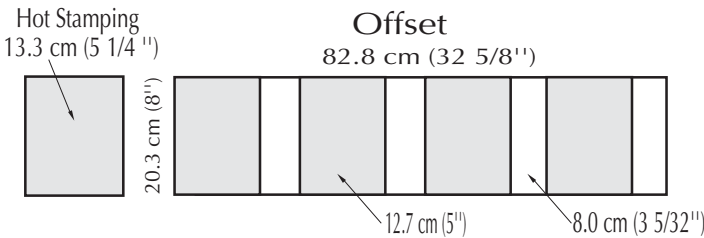

OPENING AND CLOSING

TO OPEN: For tear strip, remove tear strip, then lift cover.

TO CLOSE: Align lid on pail and press all around with hands or use a rubber mallet. Lid presses can be used (roller type or moving plate type).

PACKAGING OF EMPTY PAILS/LIDS

WAREHOUSING OF EMPTY PAILS: 2 pallets high in warehousing

Approved by:

IPL Plastics Ltd.
 20 Boyd Street
 P.O. Box 213
 Edmundston, NB
 Canada E3V-3K8
 Tel : (506) 739-9559
 Fax : (506) 739-6185
 Toll free (Service): 1-800-739-9595

IPL PRODUCTS, LTD.
 640 Lincoln Street
 Worcester, MA 01605
 Tel.:(508)351-6050 Fax.:(508)351-6044
 Toll free: 1-800-818-1318

Web Site
www.ipl-packaging.com

