



Shure-Lock™
CONTAINER # 26214
LID # 20114 or # 20115

TECHNICAL DATA**Capacity under lid :**

With 20114: 0.62 L / 22.15 US oz.
 With 20115: 0.60 L / 21.26 US oz.

Wall thickness (approx.) :

Container: 0.60 mm (0.027 in.)
 Lid 20114: 0.60 mm (0.026 in.)
 Lid 20115: 0.70 mm (0.029 in.)

Thermal range : 0°C (32°F) to
 82°C (180°F)

Materials : Container: polypropylene
 Lid: polypropylene

Standard colors : clear, natural and white
 other colors upon request

Weight (approx.) :

Container: 24 g (0.82 oz.)
 Lid 20114: 8.0 g (0.26 oz.)
 Lid 20115: 9.0 g (0.31 oz.)

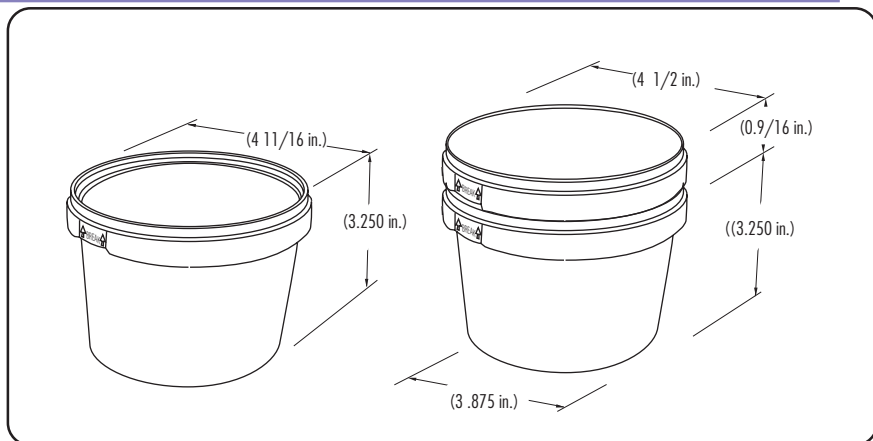
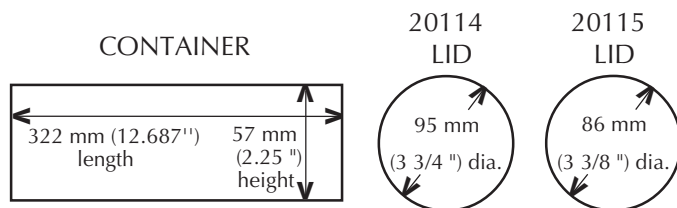

(Materials are recyclable or can be recovered for energy)

**PRINTING UP TO 6 colors, DRY OFFSET****OPENING AND CLOSING**

TO OPEN: Break the Tamper-Evident tab, then remove lid.

TO CLOSE: Snap the lid at break tab area first, then follow all around while releasing air by pressing the center of the lid to burp container. If using a closing device, use proper burping devices.

Fillers, lid, pail denesters and lidding devices are also available in a variety of combinations. Everything can be seen on brochures and video tape. Live demonstration on site can be done on demand.

PACKAGING OF EMPTY CONTAINERS/LIDS

No double stacking, racking recommended.

Approved by:

Approvals: Virgin materials are approved for food contact and meet FDA (Food and Drug Administration USA) and HPB (Health Protection Branch Canada) regulations.

Advise: Handling conditions vary a lot from customer to customer, tests are recommended throughout the process of denesting, filling, conveying, palletization, warehousing, transportation and utilization by end users, etc. Specifications can be modified without notice. Please contact your IPL representative to confirm these data.

Quality Assurance: . IPL is ISO 9001 certified and quality procedures are documented in our quality system



IPL Plastics Ltd.
 20 Boyd Street
 P.O. Box 213
 Edmundston, NB
 Canada E3V-3K8
 Tel : (506) 739-9559
 Fax : (506) 739-6185
 Toll free (Service): 1-800-739-9595

IPL PRODUCTS, LTD.
 640 Lincoln Street
 Worcester, MA 01605
 Tel.:(508)351-6050 Fax.:(508)351-6044
 Toll free: 1-800-818-1318

Web Site
www.ipl-packaging.com