

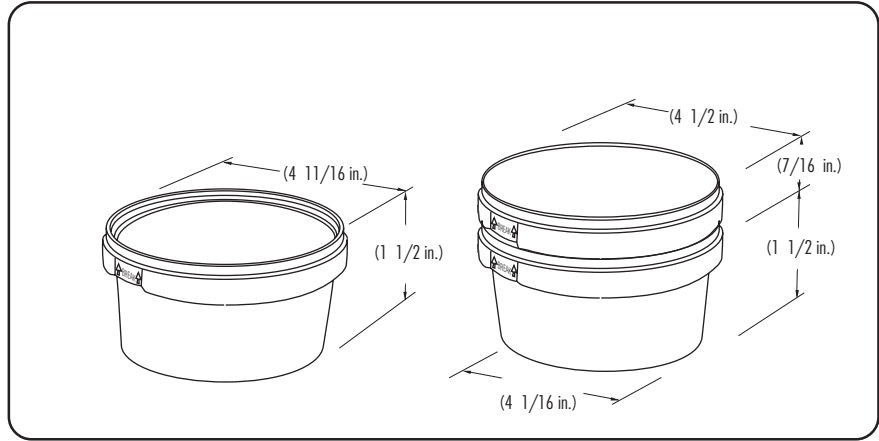

## Shure-Lock™ CONTAINER # 22314 LID # 20114 or # 20115

### TECHNICAL DATA



(Materials are recyclable or can be recovered for energy)

#### Capacity under lid :

With 20114: 0.24 L / 8.28 US oz.  
With 20115: 0.22 L / 7.44 US oz.

#### Wall thickness (approx.) :

Container: 0.53 mm (0.021 in.)  
Lid 20114: 0.60 mm (0.026 in.)  
Lid 20115: 0.70 mm (0.029 in.)

**Thermal range :** 0° C (32° F) to 82° C (180° F)



**Materials :** Container: polypropylene  
Lid: polypropylene

**Standard colors :** clear, natural and white  
other colors upon request

#### Weight (approx.) :

Container: 15 g (0.51 oz.)  
Lid 20114: 8.0 g (0.26 oz.)  
Lid 20115: 9.0 g (0.31 oz.)

### PRINTING UP TO 6 colors, DRY OFFSET

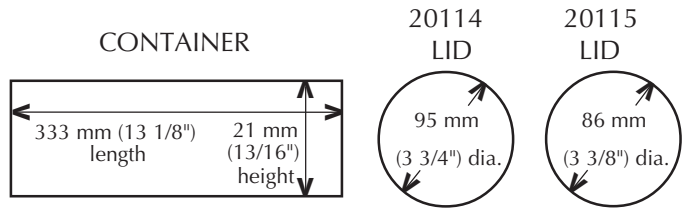

### OPENING AND CLOSING

TO OPEN: Break the Tamper-Evident tab, then remove lid.

TO CLOSE: Snap the lid at break tab area first, then follow all around while releasing air by pressing the center of the lid to burp container. If using a closing device, use proper burping devices.

Fillers, lid, pail denesters and lidding devices are also available in a variety of combinations. Everything can be seen on brochures and video tape. Live demonstration on site can be done on demand.

### PACKAGING OF EMPTY CONTAINERS/LIDS

No double stacking, racking recommended.

Approved by:

**Approvals:** ..... Virgin materials are approved for food contact and meet FDA (Food and Drug Administration USA) and HPB (Health Protection Branch Canada) regulations.

**Advise:** ..... Handling conditions vary a lot from customer to customer, tests are recommended throughout the process of denesting, filling, conveying, palletization, warehousing, transportation and utilization by end users, etc. Specifications can be modified without notice. Please contact your IPL representative to confirm these data.

**Quality Assurance:** . IPL is ISO 9001 certified and quality procedures are documented in our quality system



**IPL Plastics Ltd.**  
20 Boyd Street  
P.O. Box 213  
Edmundston, NB  
Canada E3V-3K8  
Tel : (506) 739-9559  
Fax : (506) 739-6185  
Toll free (Service): 1-800-739-9595

**IPL PRODUCTS, LTD.**  
640 Lincoln Street  
Worcester, MA 01605  
Tel.: (508) 351-6050 Fax.: (508) 351-6044  
Toll free: 1-800-818-1318

**Web Site**  
[www.ipl-packaging.com](http://www.ipl-packaging.com)