



PAIL # 63465

LID # 63334 (Snap On)
 LID # 63482 (Liquid Gasket) T.S.
 LID # 63479 (Rubber Gasket) T.S.
 LID # 60367 (Snap On) T.S.

TECHNICAL DATA

Capacity under lid:
 63334: 25.16 L / 6.65 US gal.
 63482: 25.29 L / 6.68 US gal.
 63479: 25.40 L / 6.71 US gal.
 60367: 25.27 L / 6.68 US gal.

Wall thickness:
 Pail: (0.094 in.)
 Lid 63334: (0.064 in.)
 Lid 63482: (0.072 in.)
 Lid 63479: (0.065 in.)
 Lid 60367: (0.070 in.)

Material: Pail & lid: HDPE
Thermal range: -38°C (-36°F) to 82°C (180°F)
Standard color: white
 Other colors upon request

Weight (approx.) without handle or gasket:
 Pail: (1.085 kg) 38.27 oz
 Lid 63334: (156 g) 5.5 oz
 Lid 63482: (215 g) 7.6 oz
 Lid 63479: (225 g) 7.9 oz
 Lid 60367: (182 g) 6.4 oz

Handle: metal (with plastic grip)

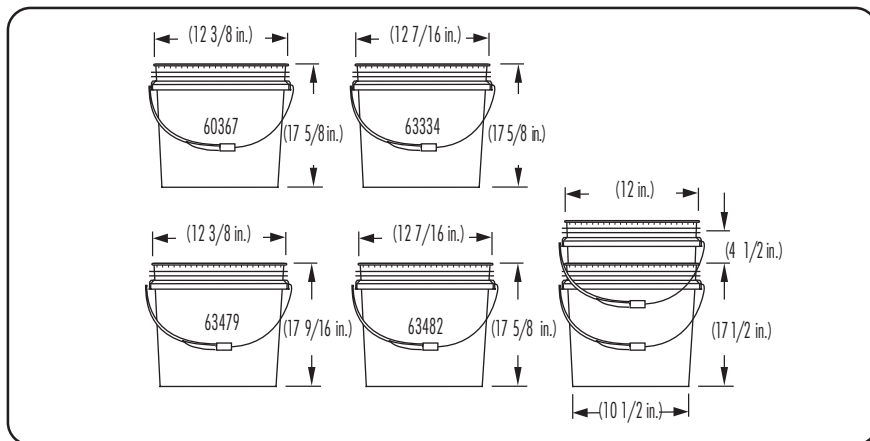

(Materials are recyclable or can be recovered for energy)

PRINTING UP TO 4 COLORS DRY OFFSET

TOP LOADING RESISTANCE

192 kg (422 lb) at 23°C / 73°F, 30 days. Product temperature when filling pails and warehouse temperature will affect pail performance. IPL recommends to make necessary testing prior to full production.

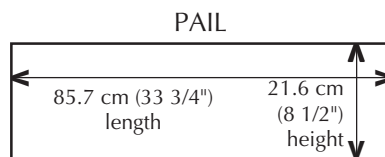

PALLETIZATION OF FILLED PAIS

To determine the number of pails you can stack according to the product packed, divide the top loading resistance by the total weight of one filled pail. Take that number not rounded up and add the first unit

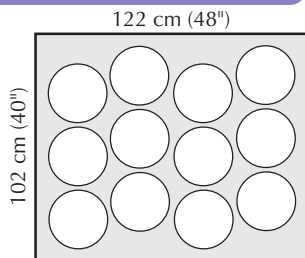

12 pails per layer
Stacked pails recommendation:
3 pails high/ pallet

RECOMMENDATIONS

- Do not exceed pallet edges with pails
- Staggered pattern is recommended for greater stability
- Double faced pallets with close together boards on both sides are recommended for best results
- To improve stability, release air from pail when putting the lid
- Stretch wrapping machine tension should be adjusted to pail
- Use slip-sheet to improve pails stability if necessary

OPENING AND CLOSING

TO OPEN: For tear strip lid, pull the tear strip then lift cover. Pry off with hands or use a lid opener for other lid.

TO CLOSE: Align lid on pail and press all around with hands or use a rubber mallet. Lid presses can be used (roller type or moving plate type).

PACKAGING OF EMPTY PAIS/LIDS

WAREHOUSING OF EMPTY PAIS: 2 pallets high in warehousing

Approved by:

Approvals: Virgin materials are approved for food contact and meet FDA (Food and Drug Administration USA) and HPB (Health Protection Branch Canada) regulations.

Advice: Handling conditions vary a lot from customer to customer, tests are recommended throughout the process of denesting, filling, conveying, palletization, warehousing, transportation and utilization by end users, etc. Specifications can be modified without notice. Please contact your IPL representative to confirm these data.

Quality Assurance:... IPL is ISO 9001 certified and quality procedures are documented in our quality system.

USA
IPL PRODUCTS, LTD.
 640 Lincoln Street
 Worcester, MA 01605
 Tel.:(508)351-6050 Fax.:(508)351-6044
 Toll free: 1-800-818-1318

Canada
IPL INC.
 140 Commerciale
 St-Damien, QC
 Canada G0R 2Y0
 Tel : (418) 789-2880
 Fax : (418) 789-3153
 Toll free: 1-800-463-0270 Ext. 299

Web Site
www.ipl-packaging.com

