



BARREL
60236

LID # 63369
-04 with gasket

steel ring # 67028

TECHNICAL DATA

- Capacity under lid:**
134.8 L / 35.61 US gal.
- Wall thickness:**
Barrel: (0.145 in.)
Lid: (0.146 in.)
- Materials:** HDPE
- Thermal range:**
-38 C (-36 F) to 82 C (180 F)
- Standard color :** white.
Other colors upon request
- Metal handle made of 1 gauge galvanized steel**

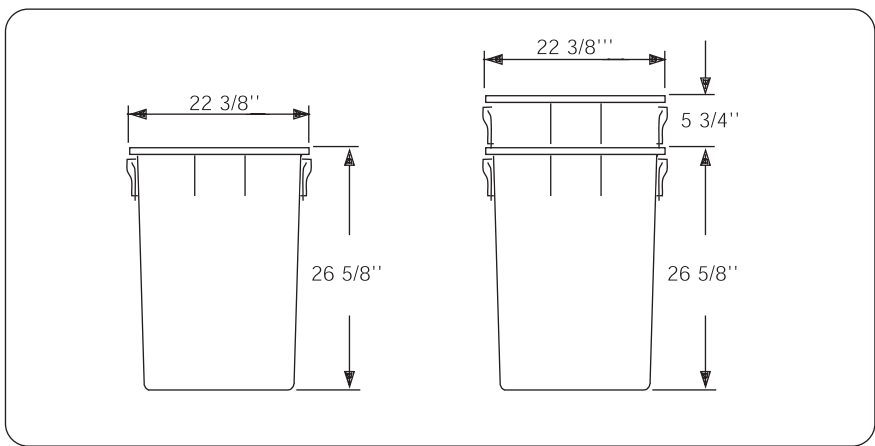

(Materials are recyclable or can be recovered for energy)

TOP LOADING RESISTANCE

IPL recommends to make necessary testing prior to full production.

PALLETIZATION OF FILLED BARRELS

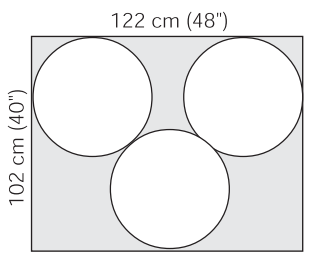

3 Barrels per pallet

RECOMMENDATIONS

- Do not exceed pallet edges with barrels
- Staggered pattern is recommended for greater stability
- Double faced pallets with close together boards on both sides are recommended for best results
- Stretch wrapping machine tension should be adjusted to barrel.

Approved by: *Stéphane Mercier*

Approvals: Virgin materials are approved for food contact and meet FDA (Food and Drug Administration USA) and HPB (Health Protection Branch Canada) regulations.

Advise: Handling conditions vary a lot from customer to customer, tests are recommended throughout the process of denesting, filling, conveying, palletization, warehousing, transportation and utilization by end users, etc. Specifications can be modified without notice. Please contact your IPL representative to confirm these data.

Quality Assurance: IPL is ISO 9001 certified and quality procedures are documented in our quality system



USA
IPL PRODUCTS, LTD.
640 Lincoln Street
Worcester, MA 01605
Tel.:(508)351-6050 Fax.:(508)351-6044
Toll free: 1-800-818-1318

Canada
IPL INC.
140 Commerciale
St-Damien, QC
Canada G0R 2Y0
Tel : (418) 789-2880
Fax : (418)789-3153
Toll free: 1-800-463-0270 Ext. 299

Web Site
www.ipl-packaging.com