

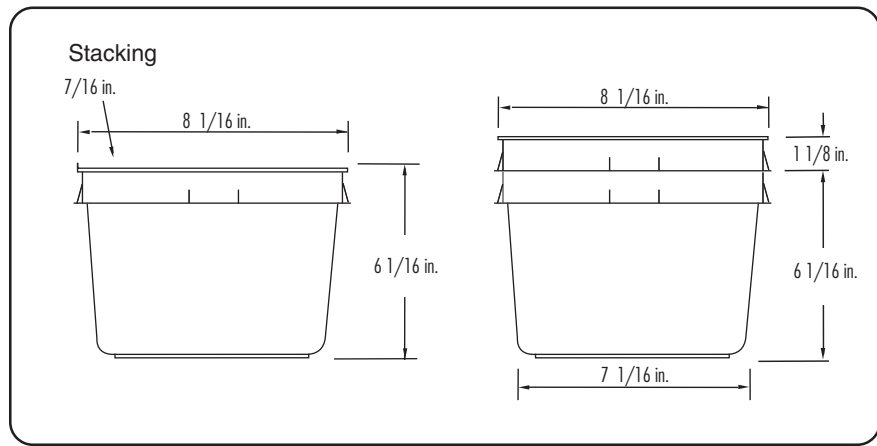

**CONTAINER # 60384
LID # 60390**

TECHNICAL DATA

- Capacity under lid:**
3.76 L / 1.09 US gal.
- Wall thickness:**
Container: 0.044 in.
Lid: 0.038 in.
- Material:** Cont.: HDPE
Lid: LDPE
- Thermal range:** -38°C (-36°F) to 82°C (180°F)
- Standard color:** natural
Other colors upon request
- Weight (approx.):**
Container: 127.4 g (4.49 oz.)
Lid: 40 g (1.4 oz.)



(Materials are recyclable or can be recovered for energy)

TOP LOADING RESISTANCE

35 kg (77 lb) at 23°C [73°F], 30 days. Product temperature when filling containers and warehouse temperature will affect container performance. IPL recommends to make necessary testing prior to full production.

PRINTING UP TO 6 colors, DRY OFFSET

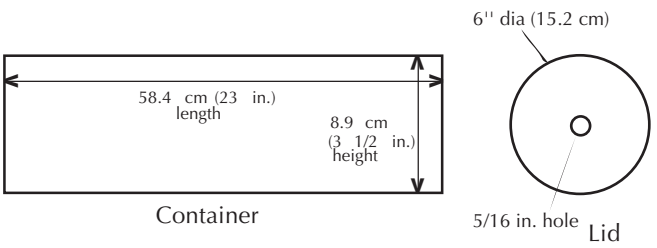

PALLETIZATION OF FILLED CONTAINERS

To determine the number of containers you can stack according to the product packed, divide the top loading resistance by the total weight of one filled container. Take that number not rounded up and add the first unit

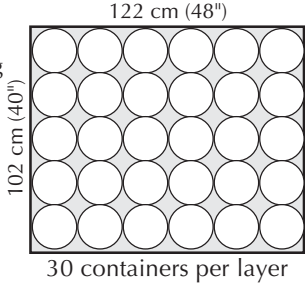

Stacked containers recommendation:
5 containers high / pallet

RECOMMENDATIONS

- Do not exceed pallet edges with containers
- Staggered pattern is recommended for greater stability
- Double faced pallets with close together boards on both sides are recommended for best results
- To improve stability, release air from container when putting the lid
- Stretch wrapping machine tension should be adjusted to container
- Use slip-sheet to improve containers stability if necessary

OPENING AND CLOSING

- TO OPEN:** Lift edge of lid at any region to remove.
- TO CLOSE:** Snap the lid at any region, then follow all around while releasing air by pressing the center of the lid to burp container. If using a closing device, use proper burping pads.

Fillers, lid, container denesters and lidding devices are also available in a variety of combinations. Everything can be seen on brochures and video tape. Live demonstration on site can be done on demand.

PACKAGING OF EMPTY CONTAINERS/LIDS

WAREHOUSING OF EMPTY CONTAINERS: 2 pallets high in warehousing

Approved by: *[Signature]*

Approvals: Virgin materials are approved for food contact and meet FDA (Food and Drug Administration USA) and HPB (Health Protection Branch Canada) regulations.

Advise: Handling conditions vary a lot from customer to customer, tests are recommended throughout the process of denesting, filling, conveying, palletization, warehousing, transportation and utilization by end users, etc. Specifications can be modified without notice. Please contact your IPL representative to confirm these data.

Quality Assurance: . IPL is ISO 9001 certified and quality procedures are documented in our quality system

USA
IPL PRODUCTS, LTD.
 640 Lincoln Street
 Worcester, MA 01605
 Tel.:(508)351-6050 Fax.:(508)351-6044
 Toll free: 1-800-818-1318

Canada
IPL INC.
 140 Commerciale
 St-Damien, QC
 Canada G0R 2Y0
 Tel : (418) 789-2880
 Fax : (418)789-3153
 Toll free: 1-800-463-0270 Ext. 299

Web Site
www.ipl-packaging.com

