



Tamper Evident PAIL # 61998

LID # 62330 or # 62344 (non-hermetic)

TECHNICAL DATA

Capacity under lid:

9.30 L / 2.46 US gal.

Wall thickness:

Pail: (0.050 in.)

Lid 62330: (0.056 in.)

Lid 62344: (0.052 in.)

Material: Pail: PP

Pail: HDPE available for freezable applications

Lid: HDPE

Thermal range: 0°C (32°F) to 82°C (180°F)**Standard color :** white or clear

Other colors upon request

Weight (approx.) without handle or gasket:

Pail: (335 g) 11.8 oz

Lid 62330: (94 g) 3.3 oz

Lid 62344: (83 g) 2.9 oz



Handle: plastic

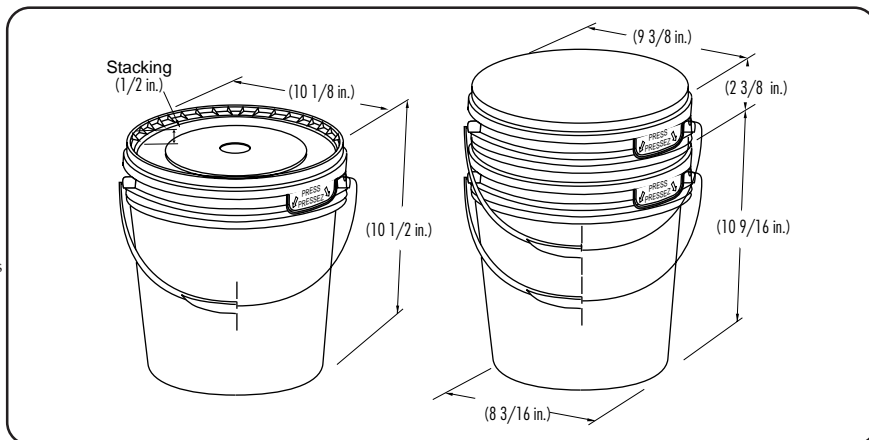

(Materials are recyclable or can be recovered for energy)

PRINTING UP TO 6 colors DRY OFFSET

TOP LOADING RESISTANCE

80 kg (176 lb) at 23°C / 73°F, 30 days. Product temperature when filling pails and warehouse temperature will affect pail performance. IPL recommends to make necessary testing prior to full production.

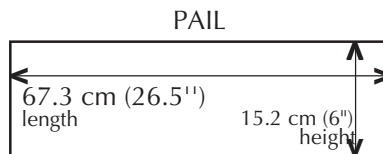

PALLETIZATION OF FILLED PAILS

To determine the number of pails you can stack according to the product packed, divide the top loading resistance by the total weight of one filled pail. Take that number not rounded up and add the first unit

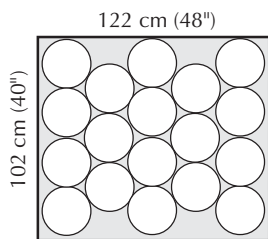

18 pails per layer
Stacked pails recommendation:
4 pails high / pallet

OPENING AND CLOSING

TO OPEN: Break the Tamper-Evident tab, then remove lid.

TO CLOSE: Snap the lid at break tab area first, then follow all around while releasing air by pressing the center of the lid to burp pail. If using a closing device, use proper burping pads.

Fillers, lid, pail denesters and lidding devices are also available in a variety of combinations. Everything can be seen on brochures and video tape. Live demonstration on site can be done on demand.

PACKAGING OF EMPTY PAILS/LIDS

WAREHOUSING OF EMPTY PAILS: 2 pallets high in warehousing

Approved by: *Stéphane Mercier*

Approvals: Virgin materials are approved for food contact and meet FDA (Food and Drug Administration USA) and HPB (Health Protection Branch Canada) regulations.

Advice: Handling conditions vary a lot from customer to customer, tests are recommended throughout the process of denesting, filling, conveying, palletization, warehousing, transportation and utilization by end users, etc. Specifications can be modified without notice. Please contact your IPL representative to confirm these data.

Quality Assurance:... IPL is ISO 9001 certified and quality procedures are documented in our quality system.



USA
IPL PRODUCTS, LTD.
640 Lincoln Street
Worcester, MA 01605
Tel.: (508) 351-6050 Fax.: (508) 351-6044
Toll free: 1-800-818-1318

Canada
IPL INC.
140 Commerciale
St-Damien, QC
Canada G0R 2Y0
Tel : (418) 789-2880
Fax : (418) 789-3153
Toll free: 1-800-463-0270 Ext. 299

Web Site
www.ipl-packaging.com